

# ADVANCE™ Series 1610B/1620B Gas Detector & Sensor

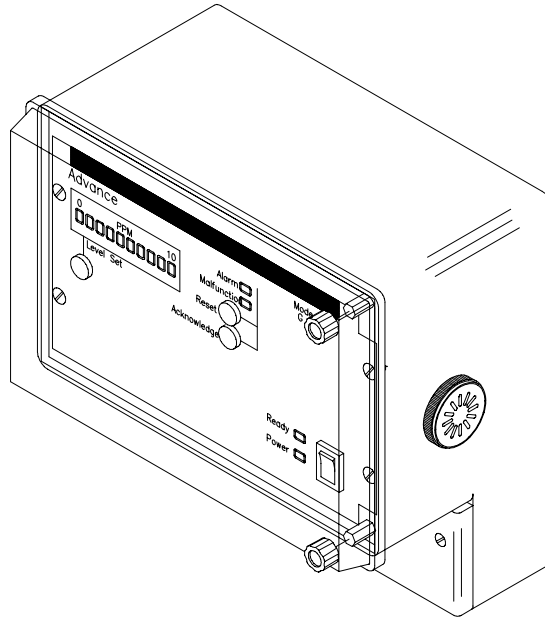

## CAPITAL CONTROLS



Series 1610B

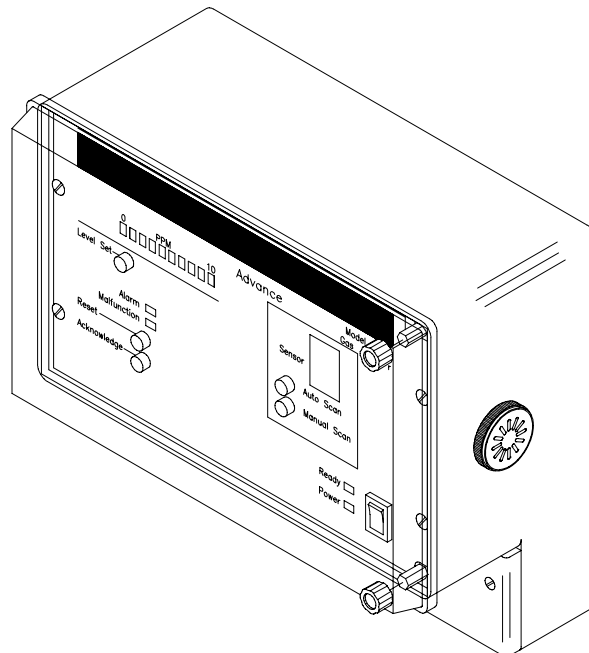

Series 1620B

These instructions describe the installation, operation and maintenance of the subject equipment. Failure to strictly follow these instructions can lead to an equipment rupture that may cause significant property damage, severe personal injury and even death. If you do not understand these instructions, please call Severn Trent Water Purification for clarification before commencing any work at 215-997-4000 and ask for a Field Service Manager. Severn Trent Water Purification, Inc. reserves the rights to make engineering refinements that may not be described herein. It is the responsibility of the installer to contact Severn Trent Water Purification, Inc. for information that cannot be answered specifically by these instructions.

**Any customer request to alter or reduce the design safeguards incorporated into Severn Trent Water Purification equipment is conditioned on the customer absolving Severn Trent Water Purification from any consequences of such a decision.**

Severn Trent Water Purification has developed the recommended installation, operating and maintenance procedures with careful attention to safety. In addition to instruction/operating manuals, all instructions given on labels or attached tags should be followed. Regardless of these efforts, it is not possible to eliminate all hazards from the equipment or foresee every possible hazard that may occur. It is the responsibility of the installer to ensure that the recommended installation instructions are followed. It is the responsibility of the user to ensure that the recommended operating and maintenance instructions are followed. Severn Trent Water Purification, Inc. cannot be responsible deviations from the recommended instructions that may result in a hazardous or unsafe condition.

Severn Trent Water Purification, Inc. cannot be responsible for the overall system design of which our equipment may be an integral part of or any unauthorized modifications to the equipment made by any party other than Severn Trent Water Purification, Inc.

Severn Trent Water Purification, Inc. takes all reasonable precautions in packaging the equipment to prevent shipping damage. Carefully inspect each item and report damages immediately to the shipping agent involved for equipment shipped "F.O.B. Colmar" or to Severn Trent Water Purification for equipment shipped "F.O.B Jobsite". Do not install damaged equipment.

**SEVERN TRENT SERVICES, COLMAR OPERATIONS  
COLMAR, PENNSYLVANIA, USA  
IS ISO 9001: 2000 CERTIFIED**

**READ THE ENTIRE MANUAL BEFORE OPERATING**

**USE ONLY IN ACCORDANCE WITH INSTRUCTION MANUAL**



**WARNING: HAZARDOUS VOLTAGES.**

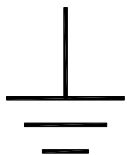

**PROTECTIVE GROUND (EARTH) TERMINAL**

**WARNING: FAILURE TO INSTALL, SET UP OR OPERATE THE GAS DETECTOR IN THE MANNER SPECIFIED BY CAPITAL CONTROLS MAY IMPAIR THE PROTECTION PROVIDED BY THIS EQUIPMENT**

**NOTICE: TEST THE SENSOR(S) AT LEAST ONCE A MONTH (ONE A WEEK IS SUGGESTED) AND AFTER EXPOSURE TO GAS. WHEN A SENSOR'S LIFE HAS EXPIRED, IT WILL NOT WARN OF A GAS LEAK.**

**WARNING: SENSOR ELEMENTS CONTAIN ACID. DO NOT DISASSEMBLE. DO NOT INCINERATE BECAUSE THE SENSOR ELEMENTS ARE SEALED AND CAN EXPLODE.**

---

---

# Table Of Contents

<b>SAFETY .....</b>	<b>4</b>
<b>1 INTRODUCTION .....</b>	<b>5</b>
1.1 General .....	5
1.2 Specifications .....	6
1.3 Quick Start-up .....	7
<b>2 INSTALLATION .....</b>	<b>9</b>
2.1 Mounting .....	9
2.1.1 Receiver .....	9
2.1.2 Sensor .....	9
2.2 Electrical Connections .....	9
2.2.1 Terminal Access .....	9
2.2.2 Line Power .....	9
2.2.3 Malfunction and Alarm Relays .....	13
2.2.4 Sensors .....	15
2.2.5 Remote 4-20 mAdc and Remote Alarm Outputs .....	16
<b>3 OPERATION .....</b>	<b>17</b>
3.1 Start-up .....	17
3.2 Gas Detector System Check .....	19
3.2.1 LED Indicator Functions .....	19
3.2.2 Alarm Circuit .....	19
3.2.3 Malfunction Circuit .....	19
3.2.4 Acknowledgment and Reset .....	19
3.2.5 System Test .....	20
3.3 Sensor Module Setup .....	21
<b>4 SERVICE .....</b>	<b>23</b>
4.1 Sensor Shunt .....	23
4.2 Sensor Voltage Check .....	23
4.3 Sensor Element Replacement .....	24
<b>5 TROUBLESHOOTING CHART .....</b>	<b>27</b>
<b>6 APPENDIX .....</b>	<b>29</b>
Series 1610B EC Declaration of Conformity .....	30
Series 1620B EC Declaration of Conformity .....	31
<b>FIGURES</b>	
1 Series 1610B Receiver Mounting Dimensions .....	10
2 Series 1620B Receiver Mounting Dimensions .....	11
3 Sensor Mounting Dimensions .....	12
4 Model 1610B Back Printed Circuit Board .....	12
5 Model 1620B Back Printed Circuit Board .....	13
6 Sensor Printed Circuit Board .....	15
7 Model 1610B Front Printed Circuit Board .....	17
8 Model 1620B Front Printed Circuit Board .....	18
9 Sensor Test Method .....	21
10 Shunt Wiring .....	23
11 Sensor Module Assembly .....	25

---

---

# SAFETY

The recommended operating procedures have been designed with careful attention to safety. Capital Controls has made formal safety reviews of the initial design and any subsequent changes. This procedure is followed for all new products and covers areas in addition to those included in applicable safety standards. Regardless of these efforts, it is not possible to eliminate all hazards from the equipment or to foresee every possible hazard which may occur. Safety is the responsibility of the user.

This equipment has been designed in accordance with safety specification IEC 1010-1 and ANSI/ISA S82.01 and meets the requirements for Class 1, Installation Category III equipment.

Observe the following precautions:

Observe all safety warnings marked on the equipment. These warnings identify areas of immediate hazard which could result in personal injury or loss of life.

Do not use this equipment for any purpose other than described in this instruction manual.

Disconnect power to the equipment prior to removing the lower access cover plate and making connections to the wiring terminals.

Do not operate the equipment with the lower access cover plate removed. Operation without the lower access cover plate presents an electrical shock hazard.

Use all practical safety precautions to prevent contact with energized parts of the equipment and related circuits.

Sensor contains acid, do not disassemble. Do not incinerate; sensor is sealed and may explode.

Test each sensor at least once a month (once a week is suggested) and after exposure to a gas leak. When a sensor's life has expired, it will not respond to testing.

Use the recommended connection procedures described elsewhere in this manual.

This equipment operates from a single phase power source. It requires a three-wire power cord. The voltage to ground from either pole of the power source must not exceed the maximum rated operating voltage, 240 Vac. Before making connection to the power source, determine that the voltage of the power source is correct. The power source must have a high rupture fuse or circuit breaker rated no higher than 15 amps.

Capital Controls recommends that qualified personnel install and connect this equipment. Component replacement and internal adjustments must be made by qualified service personnel.

The following warning and caution notices are used in this manual where applicable and should be strictly observed.

## WARNING

Warning, as used in this manual, is defined as a condition or practice which could result in personal injury or loss of life.

## CAUTION

Caution, as used in this manual, is defined as a condition or practice which could result in damage to or destruction of this equipment.

---

---

# 1 INTRODUCTION

## 1.1 General

Model 1610B Single Point and Model 1620B Multipoint Gas Detectors have been designed to continuously sense for chlorine or sulfur dioxide gas in one to eight separate locations, and alarm when the preset level is exceeded. An indicator displays the preset detection level and the accumulative level of gas through a color bar graph.

Typically, the Model 1610B Single Point Gas Detector is used to detect gas leaks in areas where chlorine or sulfur dioxide is stored. To provide early warning of gas leaks in large areas where changes in air flow pattern can be expected, e.g. outdoors, the Model 1620B Multipoint Gas Detector with several strategically located sensors is preferred for maximum safety.

Each gas detection system consists of one receiver and one sensing module for each location (up to eight sensors for Model 1620B).

A 4-20 mAdc output signal from the gas detector transmits the level of all channels scanned. This signal may be used for external alarms, event recording, optional Model 1630 Remote Indicator, etc.

### 1.1.1 General Limitations of Gas Detectors

#### a. What This Gas Detector Can Do

This gas detector is ac powered and has provisions for battery backup. The detector is designed to give early warning of gas. When gas is detected, an audible alarm sounds, an alarm indication is illuminated, and an alarm relay changes state to activate external devices. Such early warning is only possible if the detector is located, installed and maintained as described in this manual.

#### b. What Gas Detector's Cannot Do

Gas detectors do not prevent exposure. They may not give early enough warning if not installed properly.

Gas detectors will not work without power. Battery backup is recommended, and batteries should be tested periodically.

Gas detectors will not alarm if the gas does not reach the detector. Mount the sensing modules near the floor close to the gas source.

Gas detectors will not sound a remote warning unless the alarm output is connected to a warning device such as an audio or visual indicator.

Gas detectors cannot last forever. All gas detectors have a limited life, and exposure to high levels of gas or contaminants such as smoke can affect the sensor's life. Testing on a regular basis will help ensure your gas sensor will respond if an actual leak does occur.

## 1.2 Specifications

### 1.2.1 Receiver

**Power:** 115/230 Vac, 50/60 Hz, single phase

**Fuses:**

1610B: .25AT, 250V, 1 1/4" x 1/4" (ac and dc fuses)

1620B: .75AT, 250 V, 1 1/4" x 1/4" (ac fuse), 1.5AT, 32 V, 1 1/4" x 1/4" (dc fuse)

**Power Consumption:**

12 watts (Model 1610B)

24 watts (Model 1620B)

**Input:** 4-20 mAdc (per sensor)

**Outputs:**

**Power to Sensor:** 18-24 Vdc (per sensor)

**Indication Signal:** 4-20 mAdc into 900 ohms maximum

**Sensor Stabilizing Timer:** Jumper plug selectable 1/2, 1, 2, 4, 8, or 16 minutes

**Sensing Points:**

Model 1610B: 1

Model 1620B: 1-8 switch selectable

**Sensor Sequencing (Model 1620B):** Automatic or Manual Rate, jumper plug selectable 0.5, 1, 2, or 8 channels per second.

**Alarm and Malfunction Contacts:** 10 amps maximum at 240 Vac maximum, or 10 amps at 28 Vdc, resistive or inductive load, SPDT, (N.O./N.C.) DPDT (N.O./N.C.) by jumper selection when dedicated to alarm function

**Alarm/Malfunction Relay Reset:**

Model 1610B: Latching (manual reset) or unlatching (automatic reset), jumper selectable

Model 1620B: Latching (manual reset) only

**LED Indicators:** POWER, READY, MALFUNCTION, ALARM, BAR GRAPH INDICATOR, SENSOR INDICATOR (Model 1620B only)

**Bar Graph Indicator**

Range: 0-10 ppm

Accuracy:  $\pm 1$  Bar Segment

**Ambient Temperature:** 20°F to 150°F (-29°C to 65°C)

**Enclosure:** NEMA 4X

### 1.2.2 Sensor

Type: Electrochemical of the Micro Redox type

Gases: Chlorine or Sulfur Dioxide

Operating Temperature Range: -2°F to 131°F (-20°C to 55°C).

Operating Humidity Range: 2% to 98% R.H.

**CAUTION: OPERATION BELOW 15% R.H. FOR MORE THAN TWO WEEKS WILL DECREASE SENSOR SENSITIVITY, CAUSE UNSTABLE SENSOR OPERATION, AND MAY RENDER SENSOR INOPERATIVE.**

Response Time: 30 seconds maximum for 80% of range to 10 ppm gas.

Recovery Time: 3 minutes for 90% of range at 10 ppm.

Stabilization: 2 minutes

Expected Life: 18 to 24 months

Shelf Life (unpowered): 6 months

Output Signal: Standard 4-20 mAdc (source).

Connection Requirements: 3-conductor, #22 AWG shielded cable

Enclosure: NEMA 4X

**Interference Gases for Chlorine Sensor:**

<b>Gas</b>	<b>Concentration</b>	<b>Approximate Equivalent to Chlorine Signal</b>
Hydrogen	100 ppm	-1 ppm
Carbon monoxide	100 ppm	-1 ppm
Ethylene	100 ppm	-1 ppm
Sulfur dioxide	100 ppm	-5 ppm
Nitric oxide	100 ppm	+1 ppm
Nitrous dioxide (internal combustion engine exhaust)	10 ppm	+16 ppm

**Interference Gases for Sulfur Dioxide Sensor:**

<b>Gas</b>	<b>Concentration</b>	<b>Approximate Equivalent to Sulfur Dioxide Signal</b>
Hydrogen	100 ppm	1 ppm
Chlorine	10 ppm	< 0.6 ppm
Hydrogen Sulfide	100 ppm	200 ppm
Nitrous dioxide (internal combustion engine exhaust)	10 ppm	-10 ppm
Alcohols	100 ppm	< 1 ppm

### 1.3 Quick Start-up

**WARNING: FAILURE TO DISCONNECT POWER TO THIS EQUIPMENT PRIOR TO ACCESSING THE INTERIOR OF THE HOUSING MAY RESULT IN SERIOUS PERSONAL HAZARD FROM EXPOSURE TO LETHAL VOLTAGES.**

**CAUTION: THE FOLLOWING INSTRUCTIONS ARE PROVIDED FOR QUICK START-UP ONLY. REFER TO INSTALLATION AND OPERATION SECTIONS OF THIS MANUAL FOR COMPLETE INSTRUCTIONS. THE ENTIRE INSTRUCTION MANUAL SHOULD BE READ AND RETAINED FOR FUTURE REFERENCE.**

**CAUTION: AN ERROR IN SIGNAL WIRING WILL RESULT IN DAMAGE TO CIRCUIT BOARDS. DO NOT CONNECT OR DISCONNECT ANY WIRING WITH THE POWER ON.**

---

---

### 1.3.1 Receiver

- a. Set the **POWER SELECTOR SWITCH** located on the back printed circuit board for the available line voltage (115 or 230 Vac). (Refer to Figures 4 and 5)
- b. Connect the power cable to terminals L1 (hot) and L2 (neutral). Connect the ground to terminal **GND**.

**CAUTION: DO NOT APPLY POWER UNTIL ALL WIRING IS COMPLETED.**

- c. Connect 3-conductor, 22 gauge shielded cable between each sensor terminal on the receiver **([+] [GND] [I])** and the corresponding sensor module **([+] [G] [I])**. Connect the cable shield to the receiver sensor terminal **[GND]**.
- d. For the Model 1620B, set the Sensor Selector Switch, located on the front printed circuit board, to correspond to the number of sensors wired. Refer to Figure 8 for location of the sensor selector switch.
- e. Position the **TIMER** jumper plug, and for the Model 1620B, also the **SCAN RATE** jumper plug, for desired operation. Both jumper plugs are located on the front printed circuit board. Refer to Figures 7 and 8.
- f. Connect any remote devices to the **ALARM** and **MALFUNCTION** contact terminals. For Model 1610B only, position the relay jumper plugs located on the front printed circuit board for manual (latched position) or automatic (unlatched position) reset.

**NOTE: MALFUNCTION AND ALARM OR DUAL ALARM OUTPUT OPERATION IS JUMPER SELECTABLE.**

- g. Apply power and wait for **READY** light to illuminate.
- h. Set the alarm level on the bar graph indicator using the **LEVEL SET** push-button.

### 1.3.2 Sensor Setup

After one (1) hour of operation in a gas free environment, check the voltage at the sensor module. This should read  $0.90 \pm 0.05$  Vdc between **TP1** and **TP2** located on the sensor printed circuit board (Refer to Figure 6). If voltage in this range is not obtained, adjust the **ZERO** potentiometer located on the sensor printed circuit board until this voltage is obtained. In addition, the first bar (green) of the bar graph indicator should be illuminated. If it is not illuminated or more than one bar is illuminated, readjust the **ZERO** potentiometer until only the first bar is illuminated. The gas detector and optional equipment, if supplied, are now set up for normal operation. The gain potentiometer should *never* need to be adjusted.

---

---

## 2 INSTALLATION

### 2.1 Mounting

#### 2.1.1 Receiver (Refer to Figures 1 and 2)

The receiver must be mounted on a vibration-free, vertical surface, away from splashing liquids. Secure with three #10 screws. Locate the receiver in an inhabitable environment, such as a control room, so the display can be observed without exposing personnel to gas.

#### 2.1.2 Sensor (Refer to Figure 3)

The sensor is designed for wall mounting directly in the area being monitored. The sensor may be mounted indoors or outdoors. Adequate ventilation must be provided where amounts of an interfering gas such as tobacco smoke or exhaust fumes may be present, or the system will alarm. Locate the sensor module approximately 12" to 36" (305 mm to 915 mm) from the floor with the sensor element pointed downward.

NOTE: THE SENSOR MAY NEED TO BE RAISED IF THERE IS CONSTANT GAS PRESENT.

Recommendations for locating the sensors are:

- a. Locate the sensor near the gas source.
- b. Position the sensor in the air flow pattern.
- c. Do not mount the sensor in a dead air location such as a corner.
- d. Do not locate the sensor adjacent to a door.

Position the sensor module on a wall. The sensor element must be in the downward position. Secure with two (2) #8 screws.

### 2.2 Electrical Connections (Refer to Figure 4 for Model 1610B, and Figure 5 for Model 1620B)

#### 2.2.1 Terminal Access

**WARNING: FAILURE TO DISCONNECT POWER TO THIS EQUIPMENT PRIOR TO ACCESSING THE INTERIOR OF THE HOUSING MAY RESULT IN A SERIOUS PERSONAL HAZARD FROM EXPOSURE TO LETHAL VOLTAGES.**

Remove the two (2) screws securing the terminal cover plate and remove the plate to access the wiring terminals.

#### 2.2.2 Line Power

**NOTE: FOLLOW STEPS A-E TO CHANGE VOLTAGE SETTING OR PROCEED TO STEP F FOR WIRING LINE POWER.**

- a. Open the clear front cover on the receiver.
- b. Unfasten the four (4) screws and remove the face plate.
- c. Unfasten the four (4) standoffs and remove the front circuit board.
- d. Set the line power selector switch located on the back circuit board to the desired voltage (115 Vac or 230 Vac). (Refer to Figures 4 and 5).

**CAUTION: IMPROPER LINE VOLTAGE SELECTION CAN SEVERELY DAMAGE THE UNIT.  
CAUTION: NOISE/SURGE PROTECTIONS ARE RECOMMENDED ON POWER LINES WHICH HAVE ELECTRICAL NOISE CAUSED BY MOTORS OR LIGHTNING.**

- e. Replace the front circuit board and the four (4) standoffs and replace the front cover and the four (4) screws

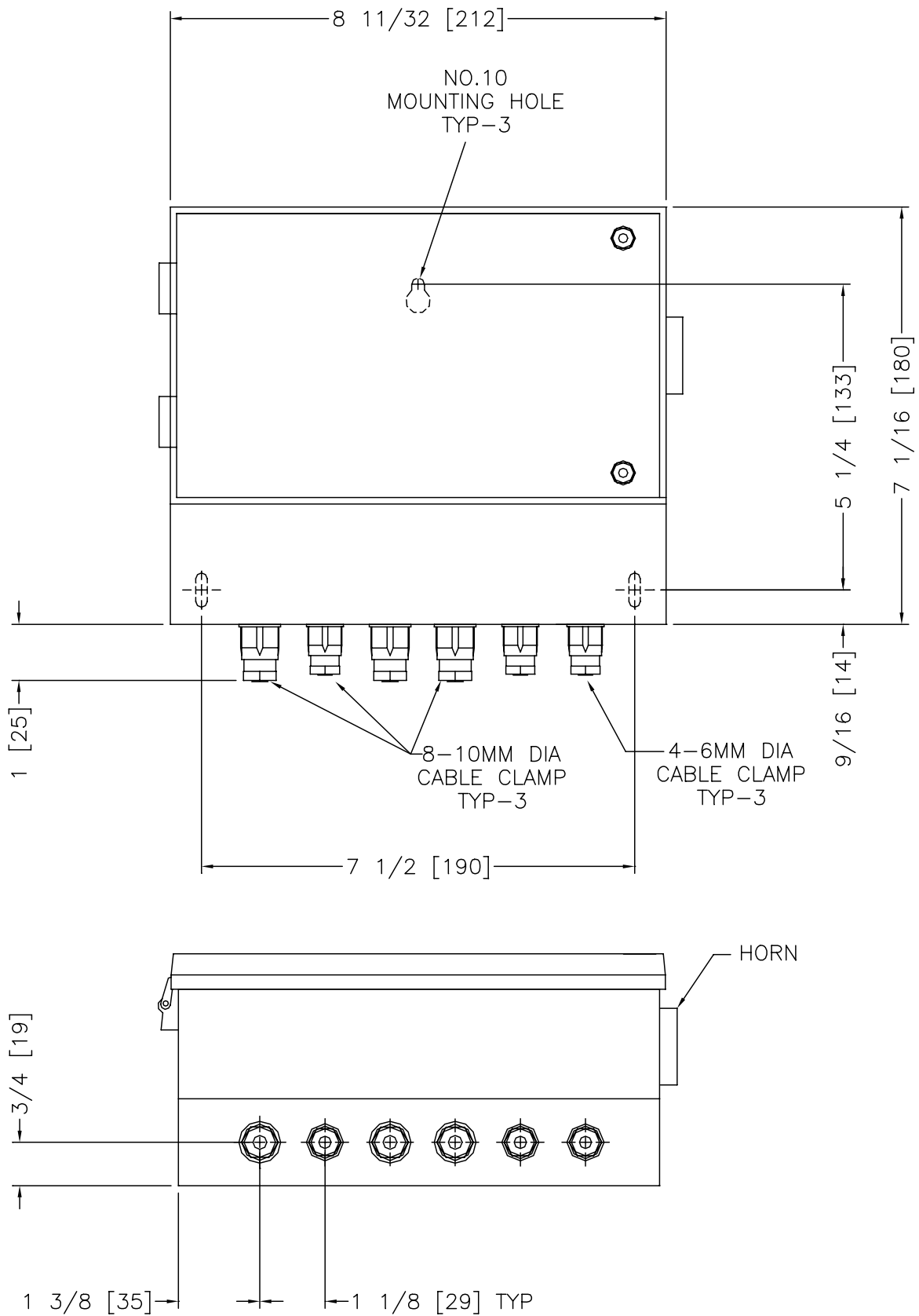
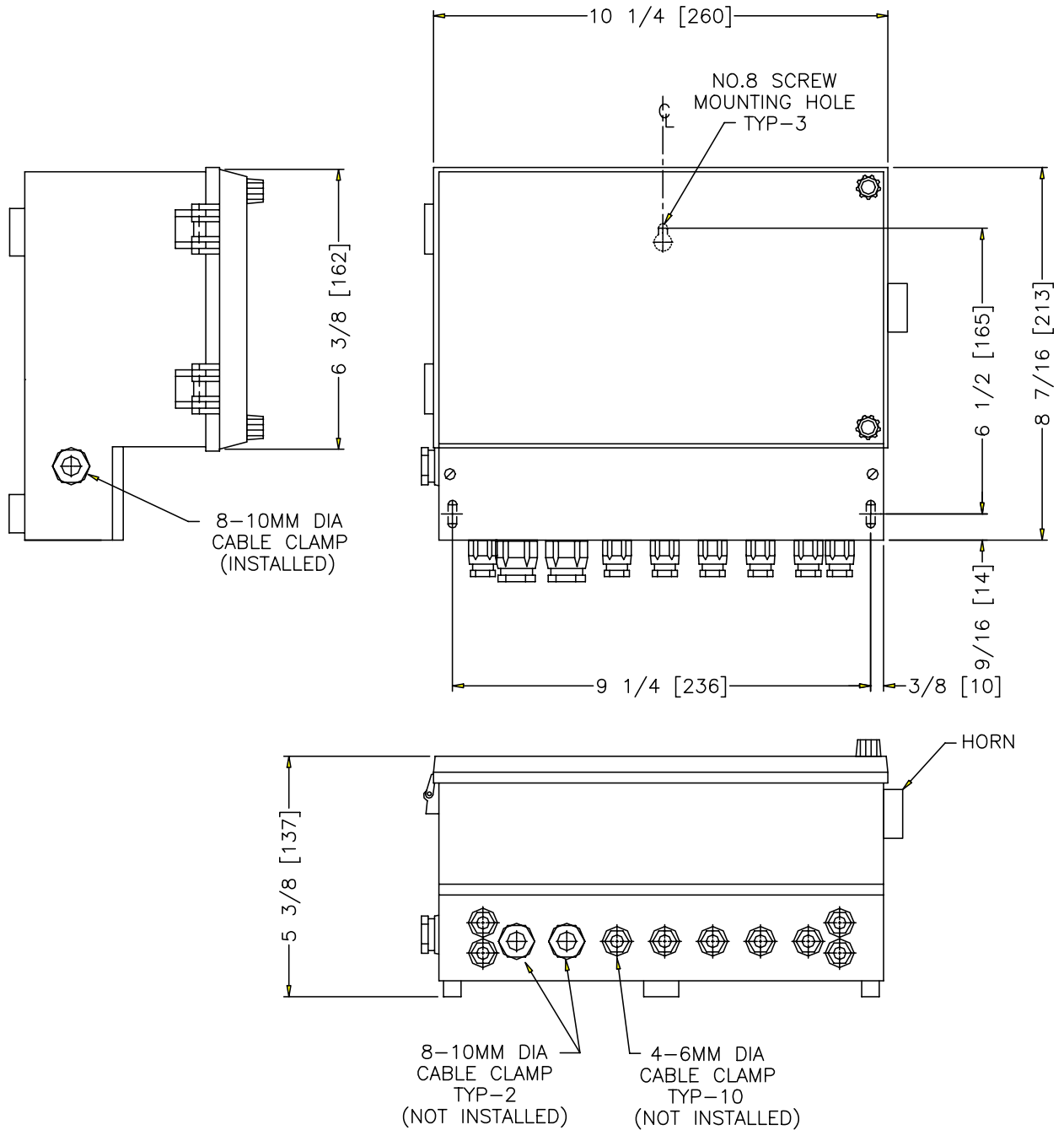

Figure 1 - Series 1610B Receiver Mounting Dimensions



LEGEND: INCHES [MILLIMETERS]

Figure 2 - Series 1620B Receiver Mounting Dimensions

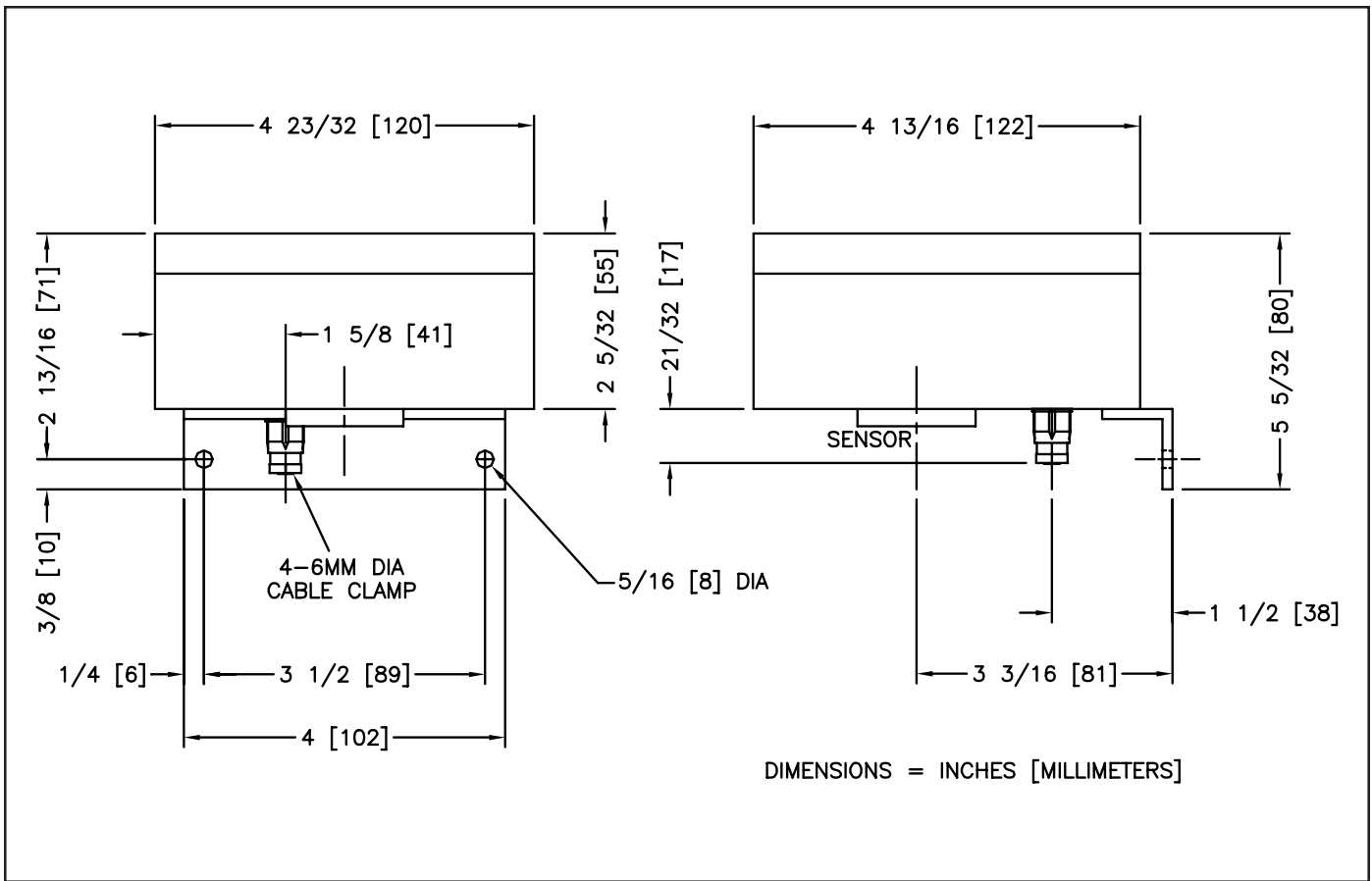

Figure 3 - Sensor Mounting Dimensions

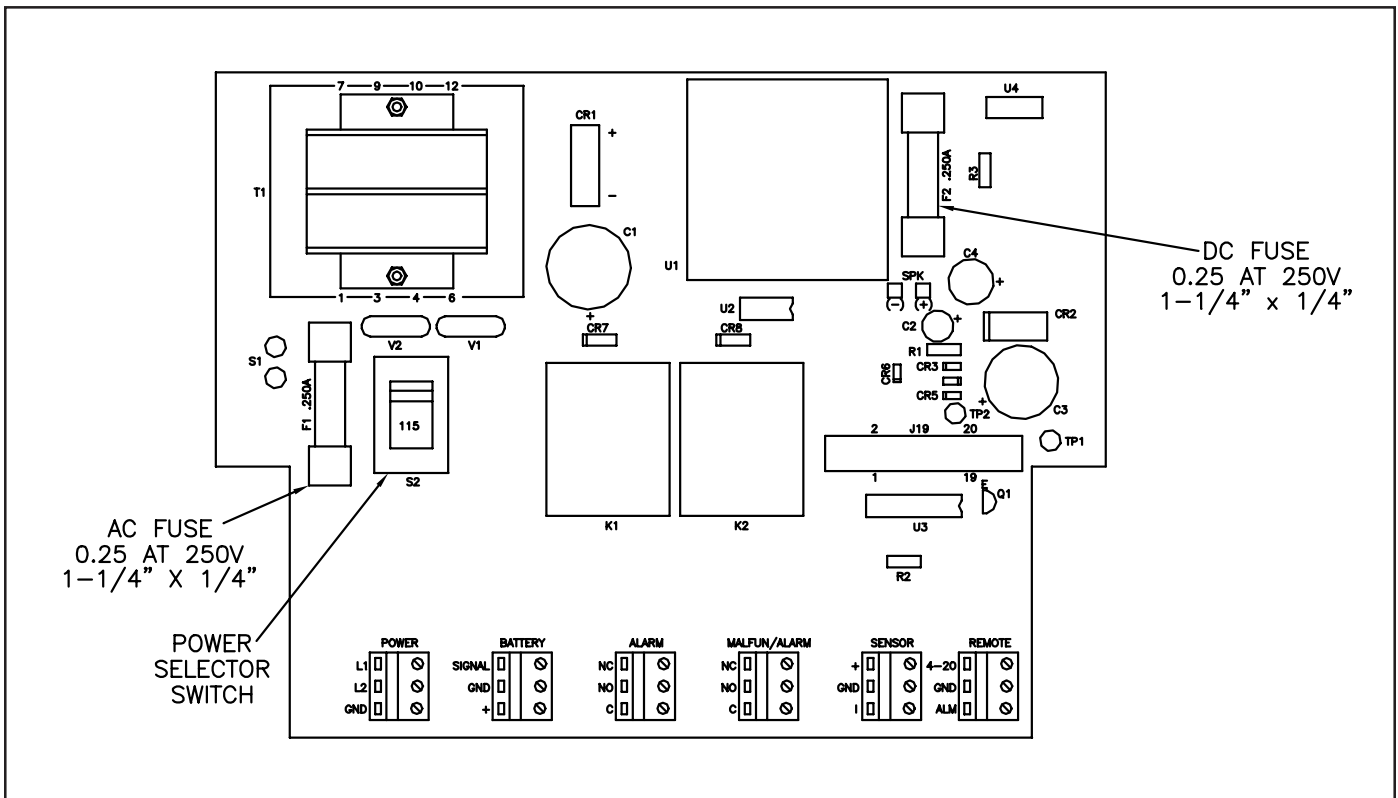

Figure 4 - Model 1610B Back Printed Circuit Board

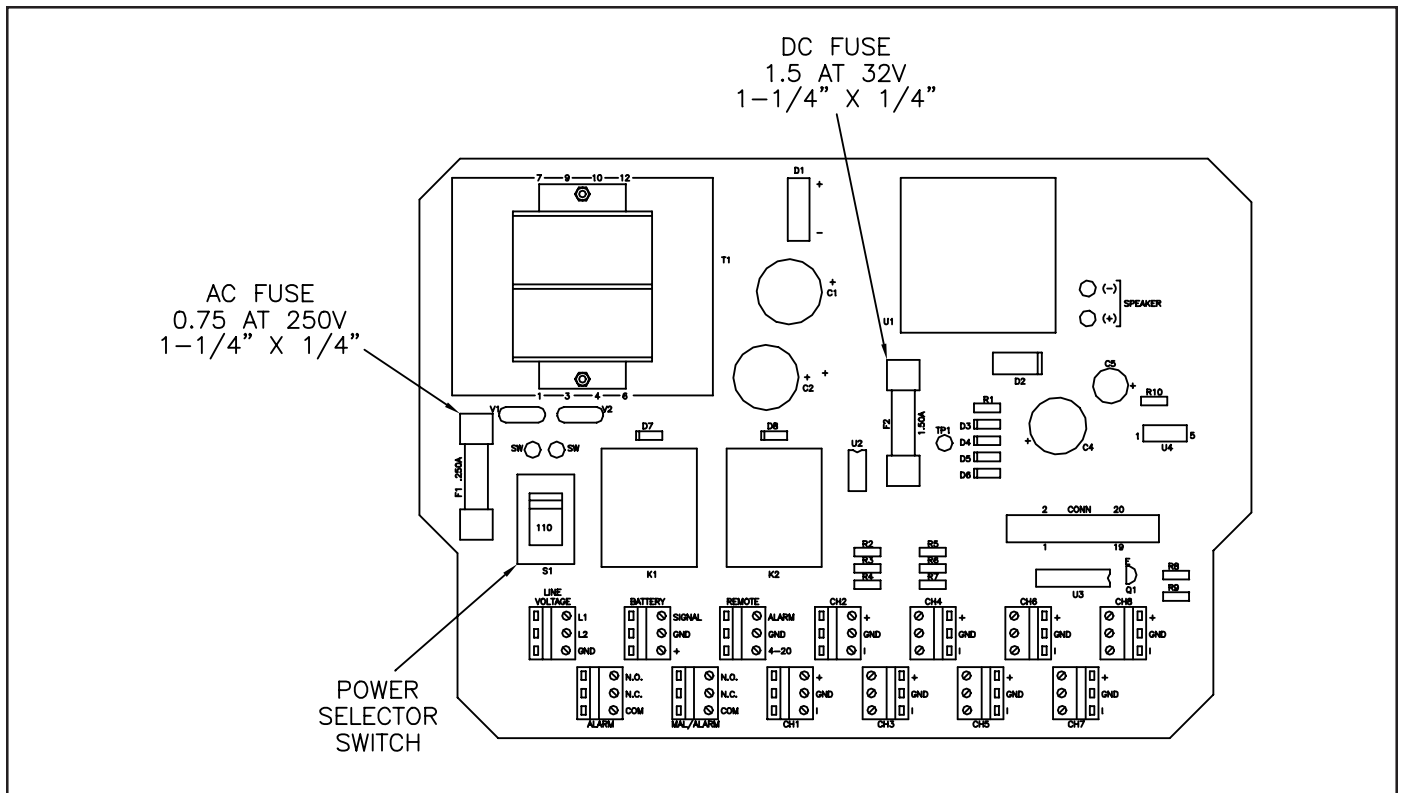

Figure 5 - Model 1620B Back Printed Circuit Board

**WARNING: POWER FOR THE GAS DETECTOR SHOULD BE SUPPLIED FROM A HIGH BREAKING CAPACITY FUSED DISCONNECT LOCATED IN CLOSE PROXIMITY TO THE UNIT.**

- f. Connect the power line to terminals marked L1 (HOT), and L2 (NEUTRAL). Connect the ground to terminal marked **GND**.

### 2.2.3 Malfunction and Alarm Relays

- a. The receivers have two relays with heavy duty contacts for connection to remote indicator devices, and control of remote devices (e.g. fans, doors, etc.), for alarm and malfunction conditions. Relay contacts are SPDT, rated 10 amps maximum at 240 Vac maximum, or 10 amps at 28 Vdc. For applications requiring dual alarm outputs, jumper positioning changes relay contact operation to DPDT. Note that with dual alarm output, a visual indication of a malfunction appears at the receiver, and at the optional Model 1630 Remote Indicator (if supplied), but there is no relay output.
- b. Connect the individual remote indicator/control devices to the relay terminal blocks marked **ALARM** and **MALFUNCTION/ ALARM**. The relay terminals are labeled NO (normally open), **NC** (normally closed), and C (common) which indicate relay status during normal (no malfunction or alarm) operation. See Start-up Section for positioning of alarm and malfunction jumpers.

### 2.2.4 Sensor (Refer to Figure 6)

- a. Adding Sensors  
There is one sensor terminal block on the Model 1610B and eight sensor terminal blocks on the Model 1620B, each consisting of three terminals labeled (+), **(GND)** and (I). Sensor modules have corresponding connections (+), **(G)**, (I).

- 
- 
1. Loosen the four (4) screws and remove the sensor module cover.
  2. Sensor connection to the receiver is made using a maximum length of 1,000 feet (305m) shielded, 3-conductor cable no smaller than 22 gauge. Model 1620B sensors should be wired in consecutive order and their locations recorded in the Appendix section.
  3. Loosen the sensor cable fitting and feed the cable through the fitting and around the printed circuit board, leaving enough slack to fasten each wire to a terminal. Strip the three (3) wires. For outdoor locations, apply silicone sealant to the cable at the fitting.
  4. Connect the shield to the receiver ground **[GND]**.
  5. Connect the positive lead from the receiver to the terminal labeled **[+]** on the sensor.
  6. Connect the ground lead from the receiver to the corresponding terminal labeled **[G]** on the sensor printed circuit board.
  7. Connect the current lead from the receiver labeled **[I]** to the corresponding terminal labeled **[I]** on the sensor printed circuit board.

**CAUTION: IF ANY OTHER WIRING COMBINATION IS USED, DAMAGE TO THE SENSOR MODULE WILL RESULT.**

8. Replace the sensor module cover and secure with the four (4) screws.
9. Tighten the gland fitting around the cable by making hand-tight, then tighten with a wrench 1 turn.

**CAUTION: INCOMPLETE TIGHTENING OF THE CABLE FITTING AND COVER SCREWS CAN ALLOW WATER TO ENTER THE ELECTRONICS MODULE WHICH WILL RESULT IN ERRATIC OPERATION.**

10. When connecting sensors to the Model 1620B, use a small, thin blade screwdriver to set selector switch located on the front printed circuit board and labeled (S6), to correspond to the number of sensors wired. Do not use positions 0 or 9. (See Figure 8)
11. To add one or more sensors, at a later date to the Model 1620B, connect the sensor(s) as described, increase the sensor selector switch (S6) setting to correspond to the total number of sensors connected to the receiver, and record the new sensor location(s) in the Appendix.

b. Removing Model 1620B Sensors

There are two methods that can be used when removing sensors connected to the Model 1620B. Method 1 generally applies when one or more sensors are temporarily removed, e.g. for servicing, and will be reinstalled. Method 2 is recommended when one or more sensors are no longer required and are permanently removed.

1. Method 1

With the power to the receiver and all associated equipment **TURNED OFF**, disconnect the wires from the sensor module and replace with a sensor shunt (Part Number A-1119). Refer to **SERVICE SECTION** for the procedure. This method will allow the circuit to be scanned and monitored as operating normally. Reapply power to the receiver and all associated equipment following shunt installation.

2. Method 2

With the power to the receiver and all associated equipment **TURNED OFF**, disconnect the sensor being removed from the receiver. Then disconnect the sensor located in the last position and reconnect it in the position previously occupied by the removed sensor. Finally, decrease the sensor selector switch (S6) position by one (Refer to Figure 8), and record the removal of one sensor and the new position of the repositioned sensor in the Appendix. Reapply power to the receiver and associated equipment.

## 2.2.5 Remote 4-20 mA and Remote Alarm Outputs

The 4-20 mA output signal is used as an output to remote devices to indicate gas detection activity in all channels being scanned. Model 1620B 4-20 mA output is indicated for each sensor as it is automatically or manually scanned. This output can be connected to the Model 1630 Remote Indicator and/or to the Model 1640 Power Back-Up. It can also be connected to an event recorder to record the magnitude and the time the event has occurred or to an auxiliary alarm. The remote alarm output provides a transition from 12 Vdc to 0 Vdc to activate the auxiliary alarm indicator and auxiliary alarm annunciator in the Remote Indicator and Power Back-Up. Refer to Bulletin 325.6020 for Model 1630 Remote Indicator instructions, and 325.6025 for Model 1640 Power Back-Up instructions. Event recorders, auxiliary alarms, etc. may be connected directly to the [4-20] and [GND] terminals on the receiver terminal block marked REMOTE when neither the Model 1630 Remote Indicator or Model 1640 Power Back-up are used. If either or both the Model 1630 or 1640 are used, then connect the device in series with the [4-20] line. Power external devices from an isolation transformer to prevent ground loops and damage to the internal components of the gas detector.

**CAUTION: THE 4-20 MADC SIGNAL IS A CURRENT SOURCE WITH THE RESPECT TO GROUND. INTERNAL COMPONENTS WILL BE DAMAGED IF THE OUTPUT IS CONNECTED DIRECTLY TO THE GROUND.**

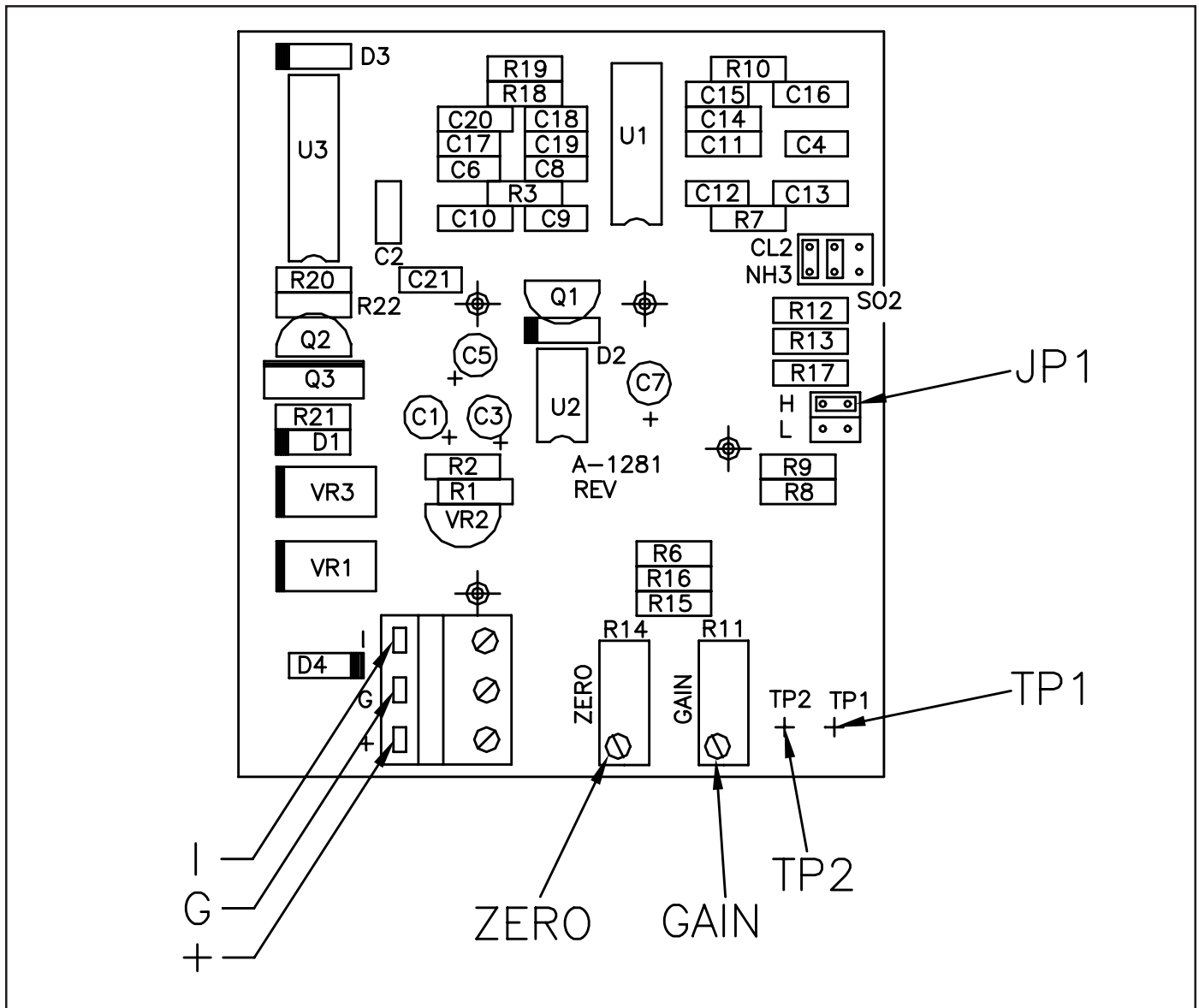

Figure 6 - Sensor Printed Circuit Board



# 3 OPERATION

## 3.1 Start-up (Refer to Figures 7 and 8)

- 3.1.1 With the power **OFF** and the face plate removed, position the timer jumper plug on the front printed circuit board (labeled **TIMER**) to the 2 minute position. This allows the sensor to stabilize.

When the selected time has elapsed, the **READY** indicator on the receiver will illuminate.

- 3.1.2 For the Model 1620B, initially set the scanning rate jumper plug located on the front printed circuit board and labeled **SCAN RATE** in the 2 Hz position. With this setting, the Model 1620B will consecutively scan two sensors connected to the gas detector every second. Other selectable scan rate settings are 0.5, 1 and 8 channels per second. Changing the scan rate increases and decreases the number of channels that are scanned per second and also affects the cycle rate of the display. The slowest scan rate is 0.5 channels per second (total scan time for 8 channels is 4 seconds), and the quickest scan rate is 8 channels per second (total scan time for 8 channels is 1 second).

- 3.1.3 For the Model 1620B, using a small, thin-blade screwdriver, position the S6 sensor selection switch located on the front printed circuit board to correspond to the number of sensors.

**CAUTION: DO NOT USE POSITIONS 0 OR 9.**

- 3.1.4 When external devices are connected to the Series 1610B relay contacts, it is necessary to configure the malfunction and alarm relays for manual reset (latched position) or automatic reset (unlatched position).

**NOTE: SERIES 1620B DOES NOT HAVE THE LATCHED OR UNLATCHED PROVISION, AND OPERATES ONLY AS A LATCHED RELAY.**

The latched position is an operational state in which the relay is energized when an alarm or malfunction condition occurs and remains energized until manually reset by pressing the **RESET** push-button located on the face plate. The unlatched position is an operational state in which the relay, after being energized by an alarm or malfunction condition, de-energizes or resets automatically when the condition is cleared.

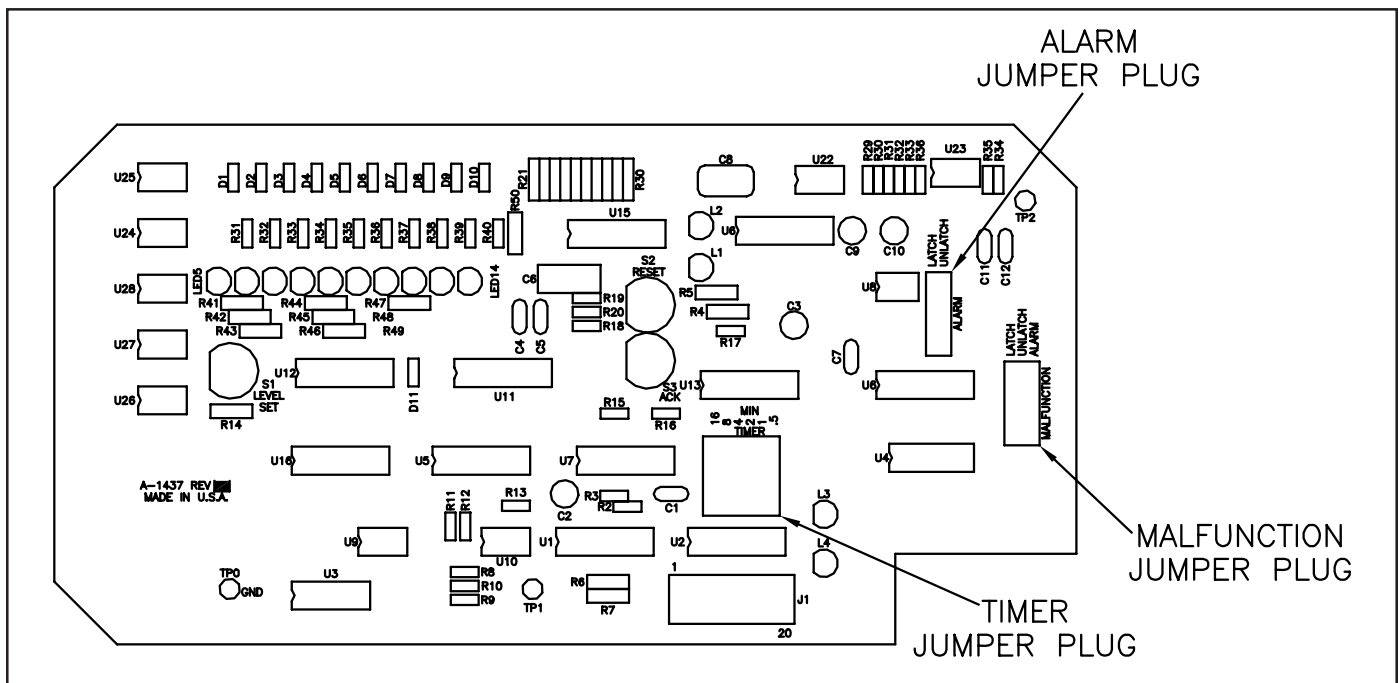

Figure 7 - Model 1610B Front Printed Circuit Board

- a. For malfunction and alarm relay outputs from the Model 1610B, place the jumper plugs on the connectors labeled **MALFUNCTION** and **ALARM** and located on the front printed circuit board in the **LATCH** (Manual reset) or **UNLATCH** (automatic reset) position.
  - b. For malfunction and alarm relay outputs from the Model 1620B, position the jumper plugs on the connector marked **MALFUNCTION** and **ALARM** and located on the front printed circuit board to the **MALFUNCTION** position. Note that the Model 1620B is designed for manual reset only.
- 3.1.5 For applications requiring dual alarm relay outputs, the receiver can be configured for DPDT operation.
- a. For dual alarm relay outputs from Model 1610B, position the jumper plug on the connector labeled **MALFUNCTION** to the **ALARM** position. Then place the jumper plug on the connector labeled **ALARM**, to the **LATCH** (manual reset) or **UNLATCH** (automatic reset) position.
  - b. For dual alarm relay outputs from the Model 1620B, position the jumper plug on the connectors marked **MALFUNCTION** and **ALARM** to the **ALARM** position.
- 3.1.6 Replace the face plate and secure with the four (4) screws.
- 3.1.7 Turn the power switch to the **ON** position. Power can be verified by the illuminated **POWER** indicator on the face plate of the gas detector. If either the ac or dc fuse is blown, the **POWER** indicator will not illuminate.
- 3.1.8 The flashing bar graph segment indicates the level set point. Set the level of sensitivity using the **LEVEL SET** push button on the face of the receiver. Depress once for each increasing level. To decrease the level, continue to depress the button until the highest value is reached. Depress the button again, and the indicator will return to its lowest position. Continue depressing until the desired value is obtained. A typical level setting would be the fifth segment (from the left) on the bar graph.

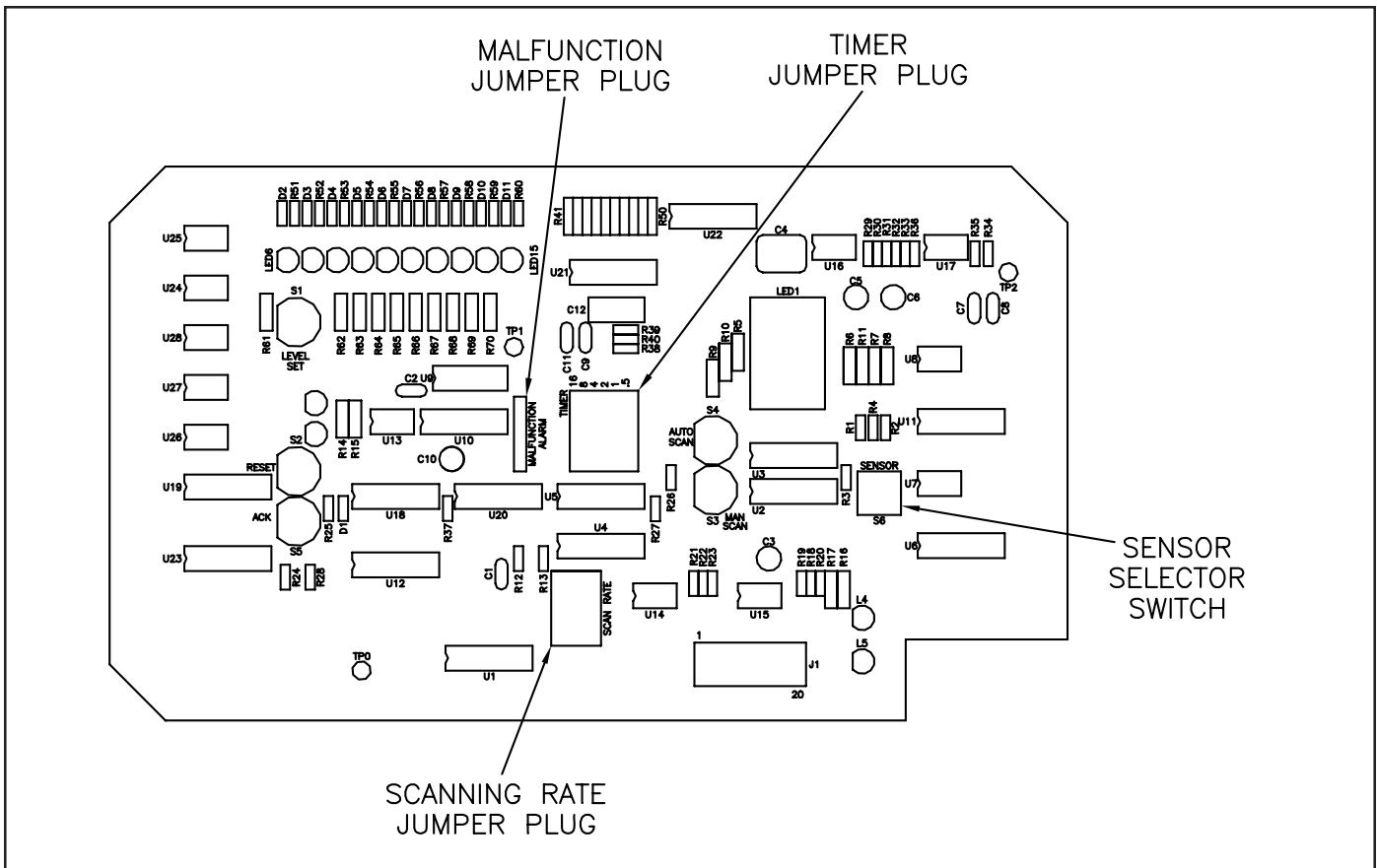

Figure 8 - Model 1620B Front Printed Circuit Board

---

---

**NOTE: THE ALARM LEVEL SETTING IS UNAFFECTED FOR UP TO 48 HOURS BY A POWER OUTAGE AND, FOR INSTALLATIONS WITH NO POWER BACK-UP, WILL RETURN TO THE PRE-OUTAGE SETTING WHEN POWER TO THE GAS DETECTOR IS REESTABLISHED.**

- 3.1.9. For Model 1620B, select either **MANUAL** or **AUTOMATIC SCANNING** by depressing either the **AUTO** or **MANUAL SCAN** button one (1) time.

To select the sensor to be scanned in the **MANUAL** mode, depress the **MANUAL SCAN** button until the desired sensor number appears on the sensor indicator. The sensors appear in descending order (highest to lowest).

- 3.1.10 When the **READY** indicator is illuminated on the face plate of the receiver, the sensors have stabilized and normal operation has begun. The first bar (green) bar on the indicator must be illuminated to indicate operative sensor circuitry. If no bar is illuminated or more than one bar is illuminated, the sensor(s) require adjustment. Refer to Sensor Module Setup Section.

- 3.1.11 Close and secure the front cover of the receiver ensuring a tight seal.

## **3.2 Gas Detector System Check**

### **3.2.1 LED Indicator Functions**

- a. **POWER** - Power applied and fuses are good.
- b. **READY** - Sensors are ready.
- c. **MALFUNCTION** - A sensor has malfunctioned.
- d. **ALARM** - Gas is present.
- e. **BAR GRAPH** - Indicates the absence or presence of gas.

### **3.2.2 Alarm Circuit**

In the presence of gas, the sensor transmits an increasing 4-20 mAdc signal. This increasing signal is displayed by accumulated bar segments on the indicator. The signal is electronically compared to the preset level and, when exceeded, the alarm circuit is activated, the relay contact closes, the **ALARM** indicator will illuminate, and the annunciator will sound. This occurs with each channel in an **ALARM** state with the Model 1620B Multipoint Gas Detector (when in the **AUTO SCAN** mode).

### **3.2.3 Malfunction Circuit**

If the 4-20 mAdc signal is not maintained, the malfunction circuit will activate. This can be caused by misadjustment of the sensor's zero voltage, loss of dc voltage to the sensor, or an open wire in the sensor cable. This will illuminate the **MALFUNCTION** indicator and the first bar on the bar graph indicator will not be illuminated. This occurs with each channel in the **MALFUNCTION** state with the Model 1620B Multipoint Gas Detector (when in the **AUTO SCAN** mode).

### **3.2.4 Acknowledgment and Reset**

The **ALARM** indicator will illuminate and the annunciator will sound whenever the preset level is exceeded. The annunciator will continue to sound until the **ACKNOWLEDGE** push-button is depressed (depressing the **RESET** push-button **WILL NOT** turn off the annunciator). Should the alarm condition persist after manual reset, the **ALARM** indicator will remain illuminated and the annunciator will sound again.

When a sensor is in either **ALARM** or **MALFUNCTION**, and the corresponding relay jumper is in the **LATCHED** (manual reset) position, that sensor cannot resume normal operation until the condition is corrected and the **RESET** button is depressed. If the corresponding relay jumper is in the **UNLATCHED** (automatic reset) position, automatic reset will occur when the condition is corrected.

If the sensor has alarmed due to the presence of gas, the gas must be evacuated and the sensor allowed to clear and stabilize. This may take as long as 3-5 minutes depending upon the concentration of the gas and the length of exposure.

### 3.2.5 System Test

**WARNING: TEST THE SENSORS AT LEAST ONCE A MONTH (ONCE A WEEK IS SUGGESTED) AND AFTER EXPOSURE TO GAS. WHEN A SENSOR'S LIFE HAS EXPIRED, IT WILL NOT WARN OF A GAS LEAK.**

**WARNING: SENSOR ELEMENTS CONTAIN ACID. DO NOT DISASSEMBLE. DO NOT INCINERATE BECAUSE THE SENSOR IS SEALED AND CAN EXPLODE.**

**CAUTION: OPERATION BELOW 15% R.H. FOR MORE THAN TWO (2) WEEKS WILL DECREASE SENSOR SENSITIVITY, CAUSE UNSTABLE SENSOR OPERATION, AND MAY RENDER SENSOR INOPERATIVE.**

**CAUTION: EXPOSURE OF THE SENSOR TO SOLVENT VAPORS, SUCH AS ACETONE AND ALCOHOL WILL MAKE IT TEMPORARILY INSENSITIVE.**

Capital Controls recommends the use of the Gas Sensor Test Kit (part number BM-4709) to periodically test the operation of the Chlorine or Sulfur Dioxide Gas Detector systems.

The Test Kit produces small quantities of chlorine or sulfur dioxide gas in a concentration of approximately 50 ppm (parts per million).

- a. Kit Contents
  - 1. Instructions
  - 2. Chlorinated Concentrate (99% Sodium Dichloro-s-triazinetriene, 55% available chlorine).

**NOTE: THIS PRODUCT IS AVAILABLE FROM POOL CHEMICAL SUPPLY STORES AND IS USED FOR HOT TUB/SPA CHLORINATION.**

- 3. Sodium metabisulfite tablets.
- 4. Boric acid
- 5. 140 ml plastic squeeze bottle.
- 6. 5 ml measuring spoon.
- 7. Gas dispenser or Calibration Cap.
- 8. Tubing

**NOTE: DISCONNECT EXTERNAL ALARMS BEFORE PROCEEDING WITH SYSTEM TESTING.**

- 1. Set the alarm level at the front panel of the Model 1610B or 1620B Receiver to the maximum value (10 ppm). On the Model 1620B, press the **MANUAL SCAN** button until the sensor to be tested is indicated.
- 2. If the receiver cannot be seen from the sensor location, have another person at the receiver, and a means of communications (e.g. telephone) available to relay information.
- 3. Place ½ spoonful of boric acid into the plastic bottle using the 5 ml measuring spoon.
- 4. Place two (2) spoonfuls of water into the plastic bottle.
- 5. To generate chlorine, place one (1) spoonful of the chlorinated concentrate into the bottle using the 5 ml spoon. Carefully shake the bottle to mix.

OR

- To generate sulfur dioxide, repeat steps 3 and 4 above, then place one (1) sodium metabisulfite tablet into the bottle. Carefully shake the bottle to mix.
- 6. Tighten the tapered cap on the squeeze bottle, and place the gas dispenser on the squeeze bottle's tapered spout. Refer to Figure 9.
  - 7. Place the dispenser over gas detector sensor. Refer to Figure 9.

8. Slowly (15-20 seconds) squeeze the plastic bottle to dispel the gas. The gas detector alarm should indicate gas presence.
9. If the gas detector does not alarm, repeat the gas application. If the detector still does not alarm, refer to the Gas Detector Troubleshooting Chart section repair procedures.
10. Reconnect external alarms.
11. Dispose of the squeeze bottle contents by flushing down the drain with cold water. Do not store mixed chemicals.
12. Make a permanent record of the test results in the back of this document.

### 3.3 Sensor Module Setup

The following equipment is required for setup:

DC voltmeter  
Small, thin-blade screwdriver

- 3.3.1 Turn on power and allow system to stabilize for one (1) hour.

**CAUTION: THIS SENSOR MODULE HAS BEEN SET AT THE FACTORY USING AN ACCURATE GAS SUPPLY. CHANGING THE SETTINGS CAN MODIFY THE ACCURACY OF THE SYSTEM. ADJUSTMENT MAY BE NECESSARY AS THE SENSOR AGES. CHECK VOLTAGES EVERY THREE (3) MONTHS.**

- 3.3.2 Connect a voltmeter to the sensor module, the ground lead to test point 1 (TP-1) and the positive lead to test point 2 (TP-2) (refer to Figure 6). The voltmeter should read 0.9 volts  $\pm$ 0.05 volt.
- 3.3.3 If adjustment is required, use the zero pot (R14) until 0.90 volts  $\pm$ 0.05 volt is achieved.
- 3.3.4 Connect a dc voltmeter between **TP1** and **TP2**. Expose the sensor to a gas source calibrated for 10 ppm. The voltage reading should go from 0.90 Vdc to 4.0 Vdc in 30 seconds. Adjustment of the **GAIN** potentiometer can increase the sensitivity as the sensor ages. If 4.0 Vdc cannot be achieved in 30 seconds, replace the sensor element.
- 3.3.5 Replace cover. Tighten cable clamp as tight as possible by hand, then one (1) turn with a wrench.

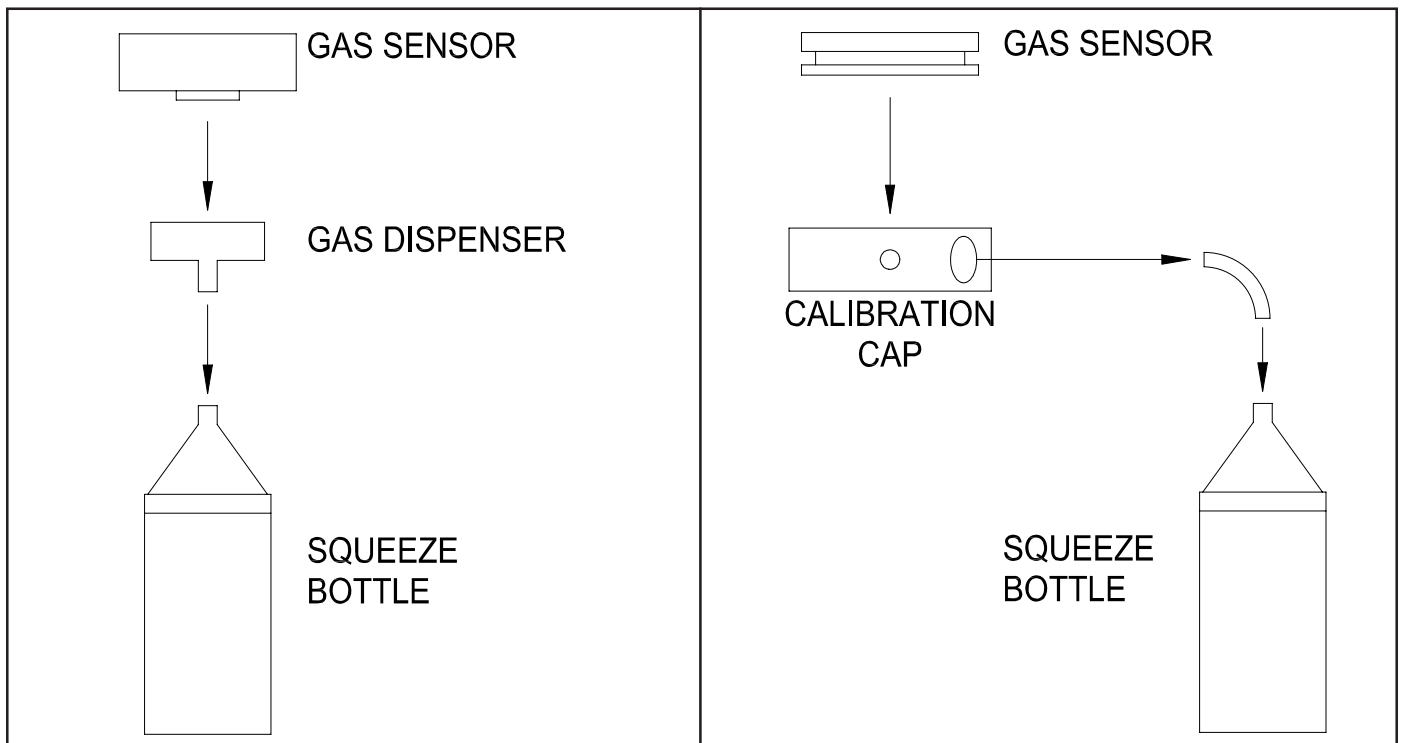

Figure 9 - System Test Method



## 4 SERVICE

**NOTE: DUE TO THE NATURE OF THIS EQUIPMENT AND THE USE OF CUSTOM-BUILT ELEMENTS, IT IS RECOMMENDED THAT THIS EQUIPMENT BE RETURNED TO THE FACTORY FOR REPAIR OR REPLACEMENT IF FOUND TO BE DEFECTIVE IN FORM OR FUNCTION.**

### 4.1 Sensor Shunt (Model 1620B only - Part Number A-1119) (Refer to Figure 10)

A shunt is used as a substitute for a sensor module by imitating a clean air signal. This will enable sensor module removal without interrupting the scanning capability of the gas detector.

- 4.1.1 Turn OFF power at the gas detector.
- 4.1.2 Remove the four (4) screws and the cover on the sensor module.
- 4.1.3 Remove the sensor module from its wall mounting.
- 4.1.4 Disconnect all wires and remove the cable.
- 4.1.5 Connect the shunt to the receiver as follows:

Receiver		Shunt
(+)	to	(+)
(GND)	to	(GND)
(I)	to	(4-20)

- 4.1.6 Turn ON power at the gas detector.
- 4.1.7 Continue normal operation of the gas detector.

### 4.2 Sensor Voltage Check

To determine correct action required for an inoperative sensor, use a voltmeter to perform the following voltage checks. Refer to Figures 4, 5, and 6.

- 4.2.1 Check the voltage between TP1 and TP2. If approximately 0.9 Vdc is measured, proceed to step 4.2.5.
- 4.2.2 Check voltage between TP1 and the (+) terminal of the cable connector. If 18 to 24 Vdc is not measured, replace the sensor circuit board.
- 4.2.3 Check the voltage between sensor cable terminals (+) and (GND) at the receiver. If 18 to 24 Vdc is not

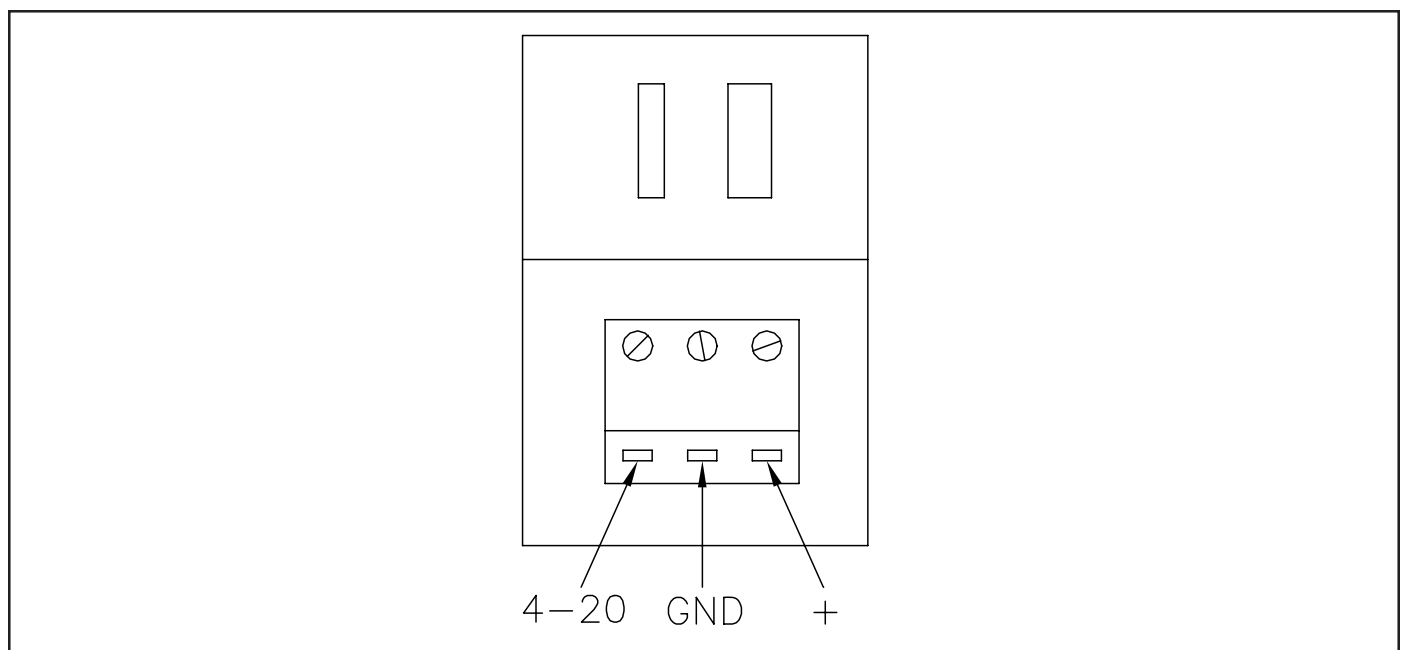

Figure 10 - Shunt Wiring

---

---

measured, replace the sensor cable.

- 4.2.4 Check fuse F2 on the back printed circuit board. If the fuse is good, replace the back printed circuit board.
- 4.2.5 Adjust the voltage between **TP1** and **TP2** for 0.90 Vdc  $\pm$ 0.05 Vdc. with the **ZERO** potentiometer. See Figure 6.
- 4.2.6 Generate and expose the sensor element to test gas by the method described in the Gas Detection System Check, Sensor Test Section.
- 4.2.7 Connect a dc voltmeter between **TP1** and **TP2**. Expose the sensor to a gas source calibrated for 10 ppm. The voltage reading should go from 0.90 Vdc to 4.0 Vdc in 30 seconds. Adjustment of the **GAIN** potentiometer can increase the sensitivity as the sensor ages. If 4.0 Vdc cannot be achieved in 30 seconds, replace the sensor element.
- 4.2.8 If the voltage between **TP1** and **TP2** does change in step 4.2.7 when the sensor is exposed to gas, then check the voltage between **TP1** and the (I) terminal of the cable connector. If the voltage does not change when the sensor is exposed to gas, replace the sensor printed circuit board.

### 4.3 Sensor Element Replacement (See to Figure 11)

**CAUTION: USE ONLY CAPITAL CONTROLS SENSOR OR THE WARRANTY IS VOID. INCORRECT OPERATION WILL RESULT IF ANOTHER SENSOR IS USED. SINCE THE UNPOWERED SHELF-LIFE OF A SENSOR IS 6 MONTHS, INSTALL REPLACEMENT SENSORS IMMEDIATELY UPON RECEIPT.**

**WARNING: SENSOR ELEMENTS CONTAIN ACID. DO NOT DISASSEMBLE. DO NOT INCINERATE BECAUSE THE SENSOR IS SEALED AND CAN EXPLODE.**

**WARNING: IF ANY MOISTURE APPEARS ON THE SENSOR ELEMENT, PROTECT YOUR HANDS WITH GLOVES, AND WIPE THE MOISTURE WITH A CLEAN, DRY CLOTH. IF ANY ACID CONTACTS YOUR HANDS, OR OTHER PARTS OF YOUR BODY OR CLOTHING, IMMEDIATELY WASH WITH SOAP AND WATER. IF ACID HAS COME IN CONTACT WITH ANY PRINTED CIRCUIT BOARDS, REPLACE THE PRINTED CIRCUIT BOARDS.**

- 4.3.1 Turn **OFF** power at the receiver.
- 4.3.2 Loosen the four (4) screws and remove the cover on the sensor module.
- 4.3.3 Remove the three (3) screws holding the sensor element assembly and the printed circuit board in the sensor module.
- 4.3.4 Unplug the sensor element from the circuit board.
- 4.3.5 Remove the shorting link from the pins on the back of the new sensor element.
- 4.3.6 Plug the new sensor element (4-pins) into the circuit board.
- 4.3.7 Reinstall the sensor element assembly and circuit board, securing them with three (3) screws.
- 4.3.8 Turn **ON** power at the receiver.
- 4.3.9 Set sensor voltage. Refer to Sensor Module Set-up section.
- 4.3.10 Replace the sensor module cover and secure with the four (4) screws.
- 4.3.11 Test the gas detector using Capital Controls Gas Sensor Test Kit, BM-4709.

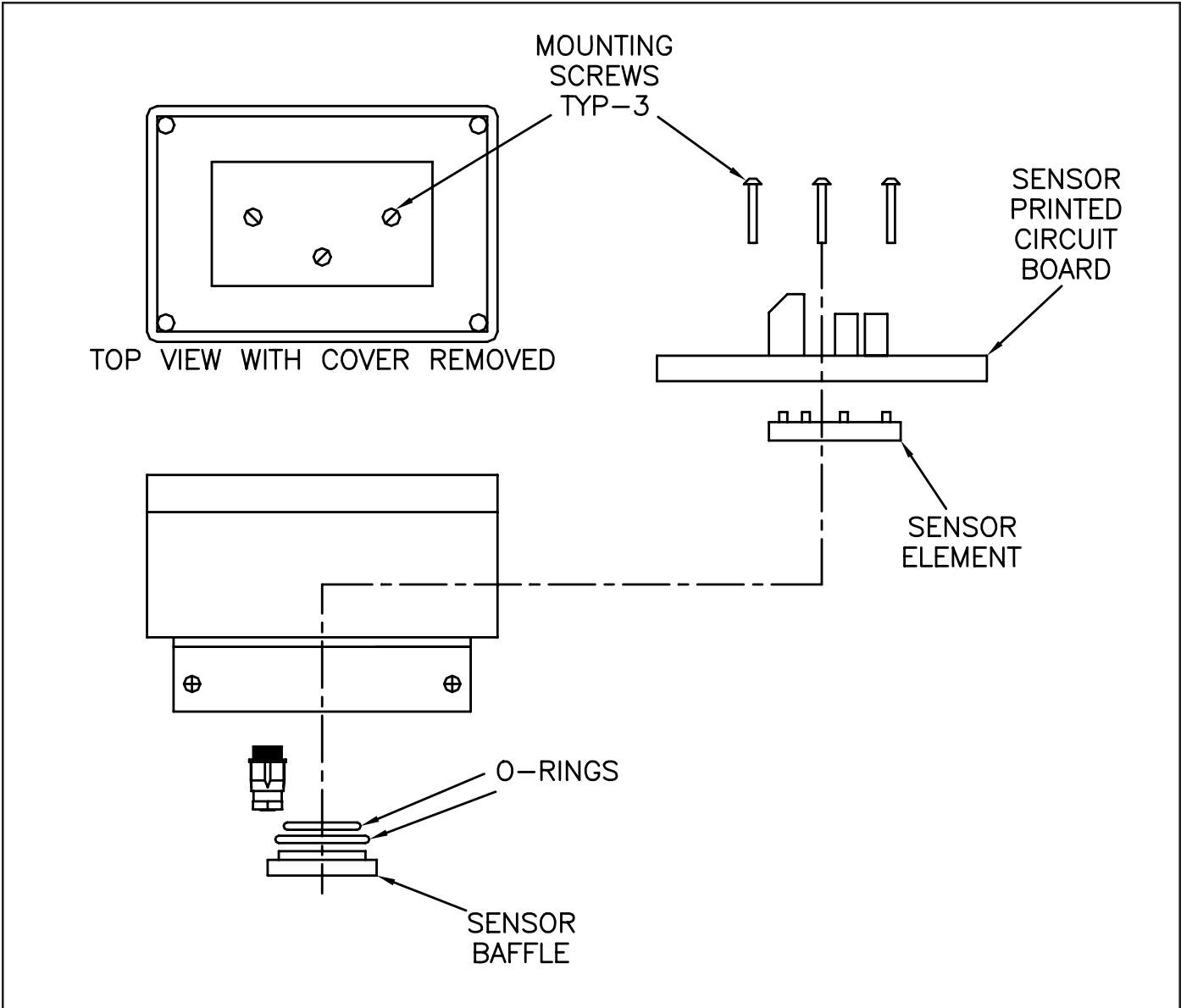

Figure 11 - Sensor Module Assembly



## 5 TROUBLESHOOTING CHART

Trouble	Probable Cause	Corrective Action
1. Insensitive sensor.	a. Sensor has aged	a. Replace sens
2. Malfunction indication on receiver.	a. Open sensor connection. b. Blown fuse F2 c. Sensor module not connected. d. Sensor Zero adjusted. e. Sensor selection switch set to correspond to the number of sensors. f. Interference from other gases.	a. Check cable connections for continuity between receiver and sensor. b. Locate and correct cause, replace fuse. c. Connect sensor or, for Model 1620B only, install shunt (See Service). d. Adjust sensor voltage. e. Reposition switch at zero. (Model 1620B only) f. Exhaust area.
3. ALARM indication but no gas	a. Intermittent failure in sensor or signal wiring (no gas hazard) b. Nitrogen dioxide (diesel exhaust) interference. c. Constant low levels of gas. d. Radio transmitter in use. e. Water inside sensor module.	a. Check cable connections and continuity between receiver and sensor. b. Relocate sensor away from diesel exhaust fumes. c. Lower sensitivity of sensor module by moving jumper JP1. d. Stop radio transmission. Relocate antenna. e. Bring sensor module indoors and dry. When installed, tighten cover and cable fitting completely.
4. Gas odor but not alarm.	a. Detector alarm set above human detection point. b. Sensor inoperative. c. Sensor exposed to solvents.	a. Reset alarm level if necessary. b. Replace sensor. c. Remove solvents and ventilate area.
5. POWER light not on.	a. Power receiver is off. b. Blown ac or dc fuse. c. Circuit breaker tripped. d. Shorted sensor cable.	a. Turn on power. b. Locate and correct cause, replace fuse. (see Note) c. Reset circuit breaker d. Repair or replace cable, replace fuse F2. (Refer to Figures 4 and 5.)
6. Unable to reset ALARM after gas leak.	a. Sensor has not cleared and stabilized. b. Gas still present c. RESET button not depressed.	a. Allow 5 minutes to stabilize b. Evacuate gas and allow sensor to stabilize. c. Depress RESET button.

**NOTE: THE AC and DC fuses are located on the power supply board. The fuses should be replaced by qualified service personnel. The Series 1610B AC and DC fuses are rated .25AT, 250 V, 1 1/4" X 1/4". The Series 1620B AC fuse is rated .75 at, 250 V, 1 1/4" X 1/4"; The DC fuse is rated 1.5AT, 32 V, 1 1/4" X 1/4". The type of fuse used in this equipment is time lage.**







Severn Trent Services Ltd  
Park Lane  
Minworth  
Sutton Coldfield  
West Midlands B76 9BL

Tel 0121 313 2300  
Fax 0121 313 1938  
www.severntrentservices.com

**EC DECLARATION OF CONFORMITY**

This is to certify that the

**Series 1610B Gas Detector**

Manufactured by  
Severn Trent Services  
3000 Advance Lane  
Colmar, Pennsylvania 18915  
Tel. 001 215 997 4000

Conforms with the protection requirements of European Council Directive 89/336/EEC as amended by 91/263/EEC & 92/31/EEC relating to Electromagnetic Compatibility and European Low Voltage Directive 93/68/EEC relating to Electrical Equipment Safety, by the application of:

Standards applied for EMC:  
BS EN 50081-1 Emission Standard  
(BS EN 55022 Class B)  
BS EN 61000-6-1

Standards applied for LVD:  
BS EN 61010-1 Safety Requirements for Electrical Equipment for Measurement Control and Laboratory Use

Tests carried out by Severn Trent Services dated March and April 1996,  
Met Laboratories, Baltimore, Maryland dated August 1996 and August 1997

**Importer into the UK**

Severn Trent Services Ltd,  
Park Lane,  
Minworth,  
Sutton Coldfield B76 9BL

**Name and Address of the Responsible Person within the EU**

**Name:** Mr. Alex Lloyd, Managing Director  
**Address:** Park Lane, Minworth, Sutton Coldfield. B76 9BL

**Signature of the Responsible person (or person empowered to sign on his behalf)**

Name **Mr. Alex Lloyd**

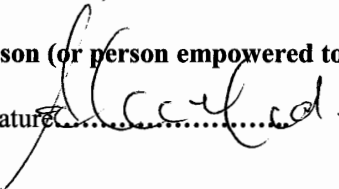
Signature 

Date **1<sup>st</sup> April 2005.**



Severn Trent Services Ltd  
Park Lane  
Minworth  
Sutton Coldfield  
West Midlands B76 9BL

Tel 0121 313 2300  
Fax 0121 313 1938  
www.severntrentservices.com

**EC DECLARATION OF CONFORMITY**

This is to certify that the

**Series 1620B Gas Detector**

Manufactured by  
Severn Trent Services  
3000 Advance Lane  
Colmar, Pennsylvania 18915  
Tel. 001 215 997 4000

Conforms with the protection requirements of European Council Directive 89/336/EEC as amended by 91/263/EEC & 92/31/EEC relating to Electromagnetic Compatibility and European Low Voltage Directive 93/68/EEC relating to Electrical Equipment Safety, by the application of:

Standards applied for EMC:  
BS EN 50081-1 Emission Standard  
(BS EN 55022 Class B)  
BS EN 61000-6-1

Standards applied for LVD:  
BS EN 61010-1 Safety Requirements for Electrical Equipment for Measurement Control and Laboratory Use

Tests carried out by Severn Trent Services dated March through November 1996, Met Laboratories, Baltimore, Maryland dated April 1997 and August 1997

**Importer into the UK**

Severn Trent Services Ltd,  
Park Lane,  
Minworth,  
Sutton Coldfield B76 9BL

**Name and Address of the Responsible Person within the EU**

**Name:** Mr. Alex Lloyd, Managing Director  
**Address:** Park Lane, Minworth, Sutton Coldfield. B76 9BL

**Signature of the Responsible person (or person empowered to sign on his behalf)**

Name **Mr. Alex Lloyd**

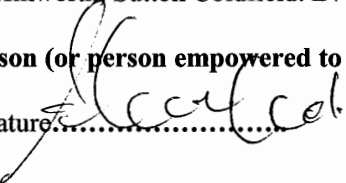
Signature 

Date **1<sup>st</sup> April 2005.**

---

---

Design improvements may be made without notice.

Represented by:



## CAPITAL CONTROLS

**Severn Trent Services**

3000 Advance Lane Colmar, PA 18915

Tel: 215-997-4000 • Fax: 215-997-4062

Web: [www.severntrentservices.com](http://www.severntrentservices.com)

E-mail: [marketing@severntrentservices.com](mailto:marketing@severntrentservices.com)

UNITED KINGDOM • UNITED STATES • HONG KONG  
INDIA • ITALY • MALAYSIA